

OTARI®

CM-20DIS

DVD Disc Inserter (Spindle Type)

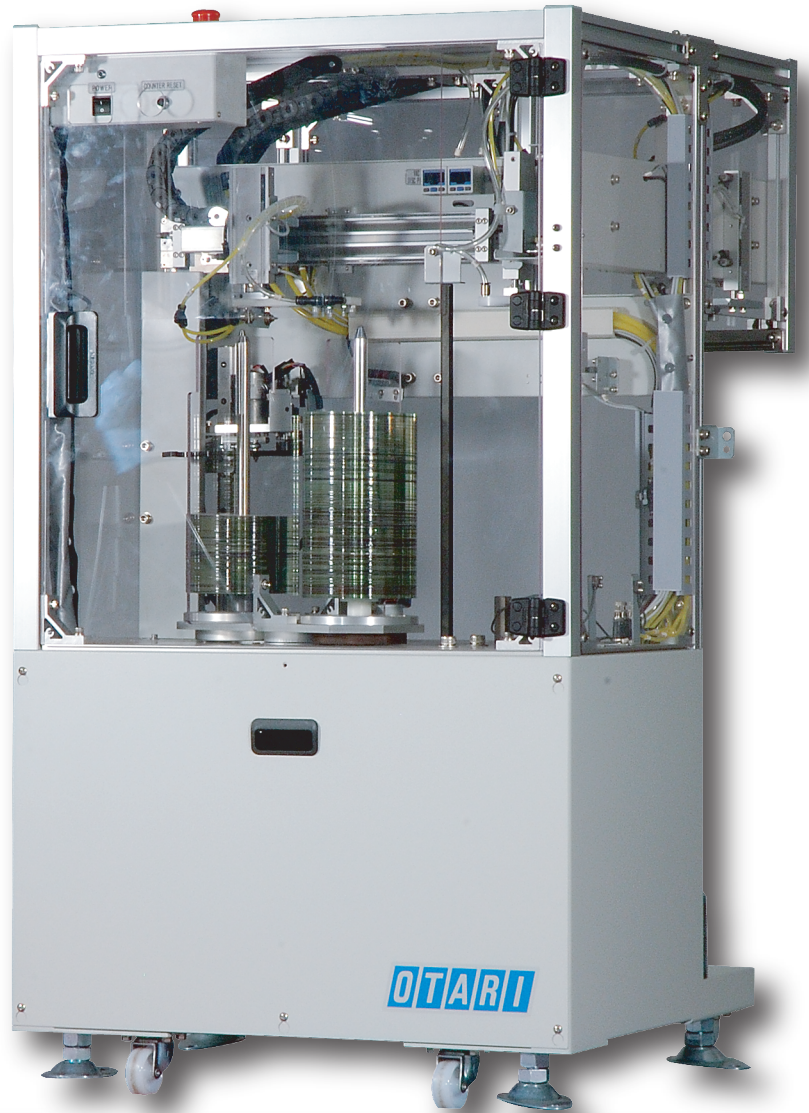

Support for Discs Stacked on Spindles

The Otari CM-20DIS DVD Disc Inserter has been designed to answer the request for a device to accept discs stacked on spindles.

Since one spindle can stack 150 discs and the machine can hold two spindles, the CM-20DIS can be loaded with 300 discs.

The CM-20DIS has a space for mounting a disc ID reader and can receive discs rejected by the ID reader.

CM-20 Series Line up

Specifications

Common to CM-20 Series Machines

Operation Speed: 20 cases per minute

Supported Case: DVD tall case (no bend or deformation)

Case Dimensions (H x W x D): 191 x 136 x 15 (regular) or 7.5 (slim) mm

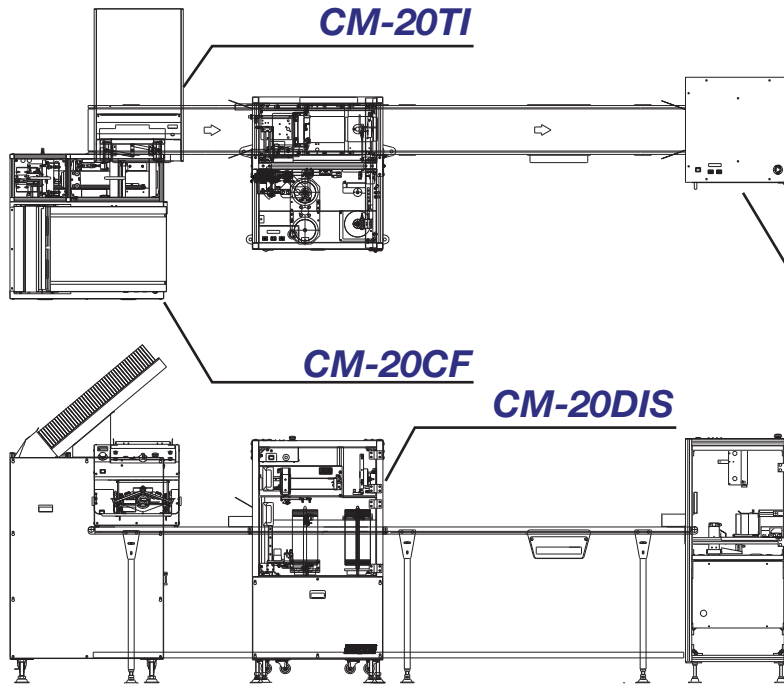

**Example of CM-20
DVD Packaging Line**

CM-20CC

CM-20CF

CM-20DIS

Disc Capacity	Approx. 150 discs x 2 spindles
Supported Disc	ø12 cm disc
Controls and Indicators	POWER switch, LCD, EMERGENCY STOP switch, START button
Dimensions (W x H x D)	620 x 1170 x 757 mm
Weight	78.5 kg
Electric Power	100–240 VAC ±10%, single phase 50/60 Hz
Power Consumption	Max. 100 VA
Compressed Air	Primary side pressure = min. 0.5 MPa (dry air)
Air Consumption	Max. 120 litre per minute (A.N.R.)
Vacuum Source	Three internal ejectors

Specifications are subject to change without notice or obligation.

CM-20 Series Line up

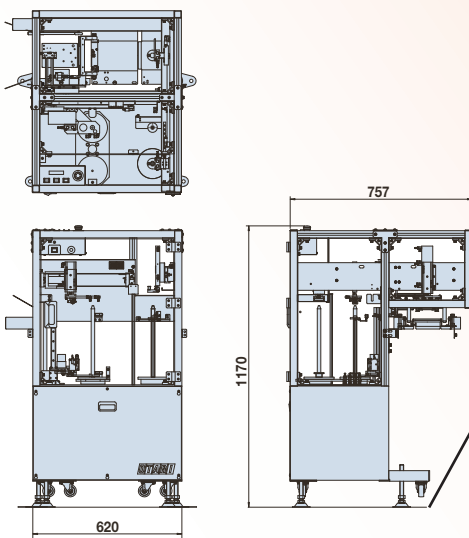

**CM-20DIS
Dimensions**

Distributed by:

OTARI
www.otari.com

Otari, Inc. 4-33-3 Kokuryo-cho, Chofu-shi, Tokyo 182-0022 Japan
Otari Singapore Pte., Ltd. 34 Jalan Jintan Singapore 229021
Otari U.S.A. Sales Inc. 21110 Nordhoff Street, Suite G/H, Chatsworth, CA 91311

☎ +81-424-81-8626 (fax: 8633)
 ☎ & fax +65-6738-7807
 ☎ +1-818-734-1785 (fax: 1786)

sales@otari.co.jp
 otaris@singnet.com.sg
 sales@otari.com